

# LIBART RETRACTABLE ROOF SYSTEM DESIGN

First Name \* :

Address :

Last Name \* :

Company :

City \* :

Phone \* :

State/Province \* :

Fax :

County :

Cell :

Zip/Postal Code \* :

E-mail \* :

Country \* :

URL:

Type :

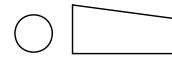
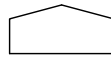

## Dimensions

L :

W :

H :

h :

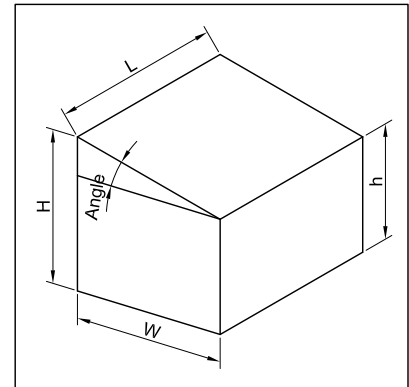
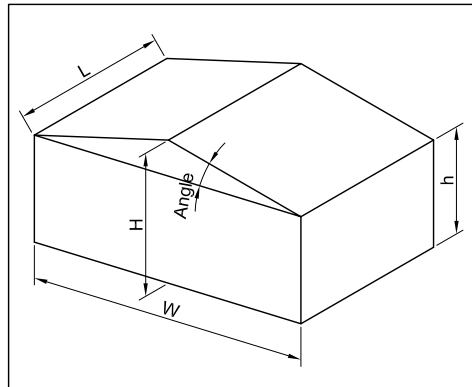

Roof Angle / Pitch :

Snow Load :

### Standard Profile :

Colour :  RAL 9010 ( Euro-White)

RAL 1019 ( Sandstone )

RAL 8014 ( Java Brown)

RAL 7039 ( Quartz Grey )

Glazing :  Clear Transparent PC

Opal Translucent PC

BronzeTransparent PC

Other ? OPAL (.....)

Measurements are in :  Feet

Meters

Operating System :  Motorized

Manual

Notes :